

## UM-3040 Input Clutch/Output Clutch Combination UM-3040-B Input Clutch/Output Clutch Combination—Base Mounted

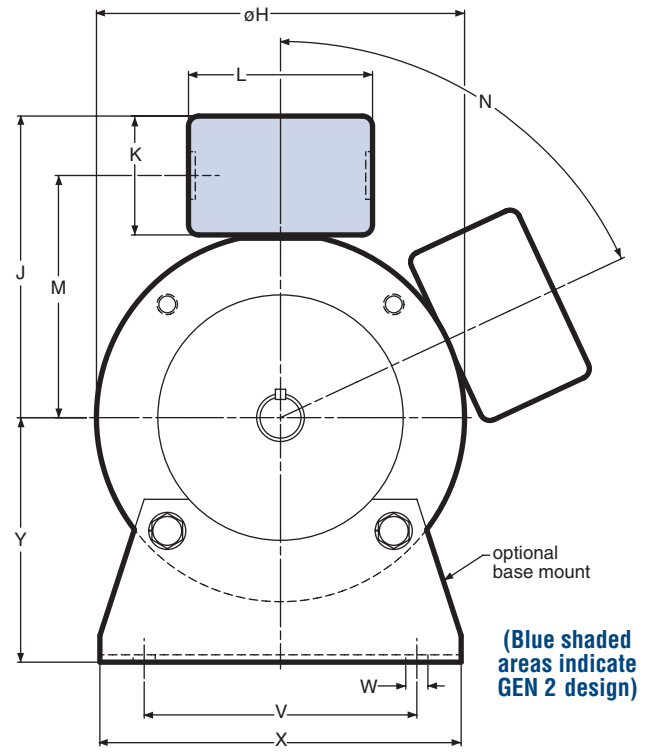
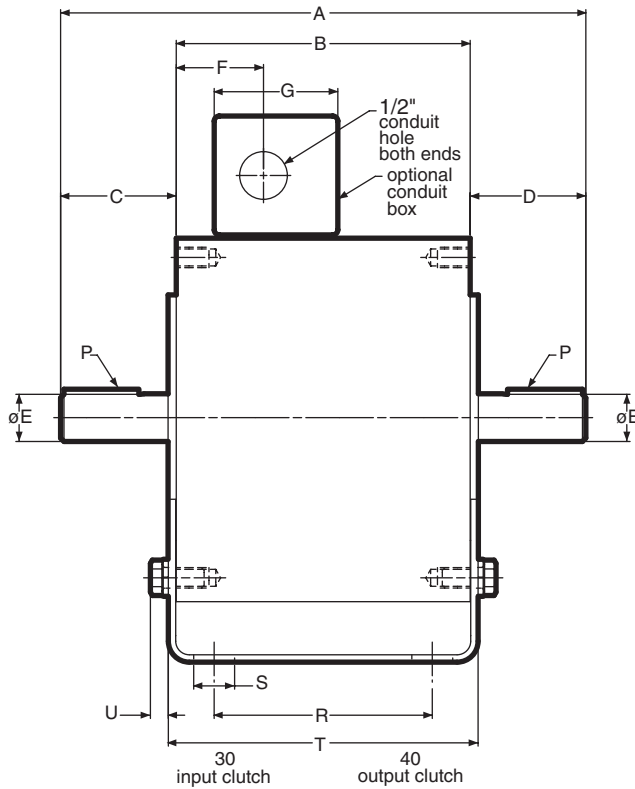

Note: Mounting base and conduit box are optional and are ordered separately.

### Dimensions (Blue shaded areas indicate GEN 2 design)

Size	A	B	C	D	E	F	G	H	J	K	L	M
50	9.492	5.390	2.062	2.040	.625	1.600	2.267	6.750	5.516	2.180	3.250	4.426
100	9.512	5.390	2.061	2.061	.625	1.600	2.267	6.750	5.516	2.180	3.250	4.426
180	9.632	5.390	2.121	2.121	.875	1.600	2.267	6.750	5.516	2.180	3.250	4.426
210	12.969	7.719	2.500	2.500	1.125	1.812	2.267	9.250	6.859	2.180	3.250	5.766
215	12.969	7.719	2.500	2.500	1.375	1.812	2.267	9.250	6.859	2.180	3.250	5.766

Size	N	P	R	S	T	U	V	W	X	Y
50	0°	3/16 x 3/16	4.000	.800	5.680	.329	5.000	.406	6.000	3.500
100	0°	3/16 x 3/16	4.000	.800	5.680	.329	5.000	.406	6.000	3.500
180	0°	3/16 x 3/16	4.000	.750	5.680	.329	5.000	.406	6.625	4.500
210	65°	1/4 x 1/4	6.000	.750	8.260	.437	7.750	.534	9.000	5.250
215	65°	5/16 x 5/16	6.000	.750	8.260	.437	7.750	.534	9.000	5.250

### Specifications (Blue shaded areas indicate GEN 2 design)

Model Size	Voltage DC	Static Torque lb. ft.	Max. RPM
50	6, 24, 90	16	3600
100	6, 24, 90	30	3600
180	6, 24, 90	30	3600
210	6, 24, 90	95	3600
215	6, 24, 90	95	3600

For standard NEMA frame dimensions, see page 64.

Only 50, 100, and 180 sizes of the models listed will be converted to the new GEN 2 design. 210 and 215 sizes will continue to be offered in the original design and will not be converted.